

# LOW COST INTELLIGENT ETHERNET THERMOMETER



- APPLICATIONS
- server rooms
- telecommunication devices
- warehouses, glasshouses
- manufacturers
- museums, archives, galleries
- air-conditioned rooms

Ethernet thermometer is designed for ambient temperature measurement and measurement from up to four external temperature cable probes.

Measurement in degrees Celsius and degrees Fahrenheit supported. Ethernet thermometer is built in a durable plastic case.

Online data acquisition system from thermometers connected to Ethernet/Internet can be easily built by means of Comet software package **Database Sensor Monitor**.

## MODES OF COMMUNICATION

ModBus TCP:	Modbus TCP protocol enables to read measured values, set alarm limits, adjust the probe, read firmware version.
Telnet:	Port 9999 enables to set alarm limits (lower and upper limits for T, RH, Tdp, hysteresis and time delay), e-mail addresses, SNMP addresses, probe description, refresh of www pages (10s to 65535s), select type of www pages, set storing interval to history (10s to 65535s), enable each communication channel. Capacity of the history memory is 600 sets of measured temperature, export to CSV file enabled. Password protection of this port is enabled. Automatic IP address assignment from DHCP server is also enabled.
www pages:	User selectable design of www pages enabling to display curves of measurement history. User can design the look of www pages and select values to display.
SNMP:	It is possible to read actual values and alarm limits. In case of alarm creation warning message (trap) is sent to IP addresses defined by the user (maximum three addresses).
SOAP:	Transmitter enables to send actual measured data in the format of SOAP message to selected web server in preset interval 10-65535 s. In case message is not received by the server till next message is sent, warning trap 1/2 is sent.

## ALARM OPTIONS

E-mail:	In case of alarm creation warning e-mail message is sent to addresses defined by the user (maximum three addresses). Basic SMTP authentication is supported.
www pages:	In case of exceeding adjusted limits of measured values active alarm is displayed at www page.
SNMP:	In case of alarm creation warning message (trap) is sent to IP addresses defined by the user (maximum three addresses).
syslog:	Transmitter enables to send text messages to selected syslog server after different events appear. E.g. after transmitter restart, alarm activation, communication error with SNTP, write to transmitter via mdb, sntp, after firmware change, after alarm termination, after communication error with SOAP server.

## TECHNICAL PARAMETERS

Supported temperature units:	degrees Celsius, degrees Fahrenheit
Temperature sensor:	digital temperature sensor Dallas DS18B20
Range and accuracy of P8511, P8541:	-55 to +80 °C, accuracy ±0.5 °C from -10 to +80 °C
Range and accuracy of P8510:	-30 to +80 °C, accuracy ±0.8 °C
Resolution:	0.1 °C
Measuring interval:	2 s
Operating temperature range:	-30 to +80 °C
Protection:	IP30
Temperature probe connector:	connector CINCH
LAN connection:	connector RJ-45
Power:	5Vdc, max. consumption 250mA, e.g. ac/dc adapter - see Optional accessory
Power connector:	axial, diameter 5 x 2.1 mm
Mechanical dimensions of model P8510:	88 x 126 x 39.5 mm (W x H x D)
Mechanical dimensions of P8511, P8541:	88 x 74 x 39.5 mm (W x H x D)
Weight:	240 g

# LOW COST INTELLIGENT ETHERNET THERMOMETER

Available thermometer models:



Model P8510 with built-in temperature sensor

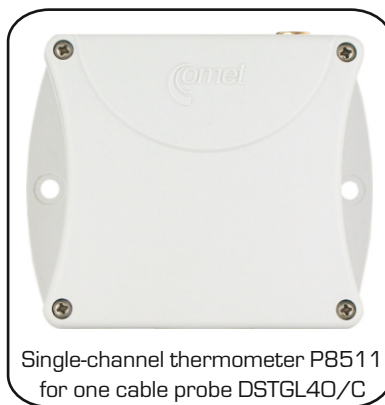

Single-channel thermometer P8511 for one cable probe DSTGL40/C



Four-channel thermometer P8541 for four cable probe DSTGL40/C

## Included accessory:

**Traceable calibration certificate** from the manufacturer with declared metrological traceability of etalons is based on requirements of EN ISO/IEC 17025 standard.

Free program TSensor for configuring of the transmitter is ready to be downloaded from [www.cometsystem.cz](http://www.cometsystem.cz).

Free program SensorReader for logging values from one thermometer to a PC disk file is ready to be downloaded. Recorded values in CSV format are easy to process in e.g. Excel.

For acquiring values from several transmitters, third party software is possible to use. Tested functionality is with programs LabVIEW, TIRS.NET, EasyView.

## Optional accessory:

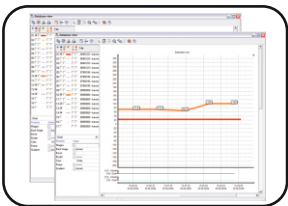

**DBS Sensor Monitor** - database program for online data acquisition and analysis from Comet sensors. It contains all necessary components for monitoring of sensors, including one licence of DBV Database Viewer.



**DSTGL40/C** - temperature probes -30 to +80 °C with digital sensor Dallas DS18B20 with Cinch connector for thermometers P8511, P8541. Stainless steel 17241 with PVC cable of specified length. Diameter 5.7mm, length 40mm. Cable lengths 1, 2, 5 or 10 meters available.

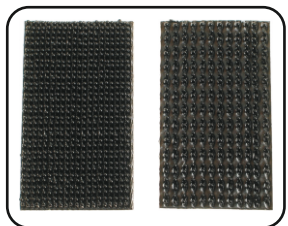

**MD036** - self adhesive Dual Lock for easy installation



**A1825** - ac/dc adapter 230V-50Hz/5Vdc. For power over Ethernet any PoE splitter is necessary - e.g. D-Link DWL-P50.

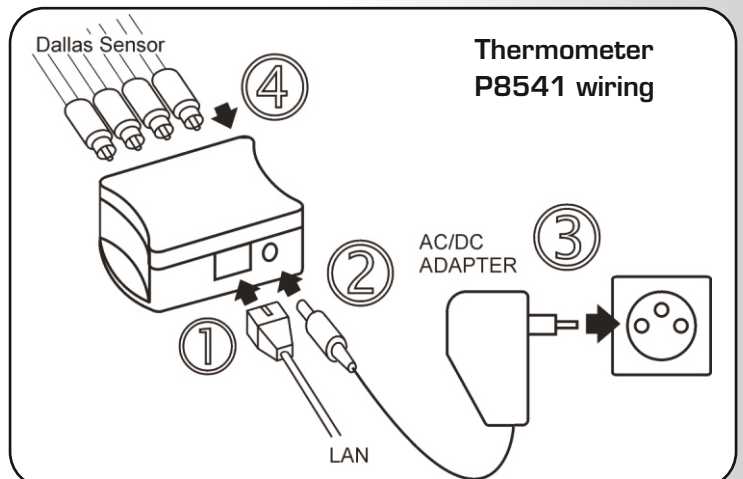
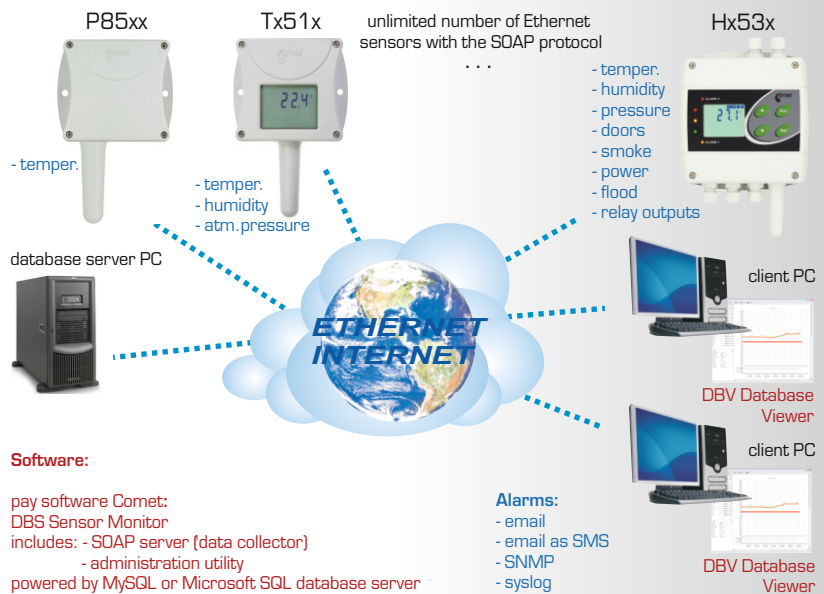

Pxxx Txxx

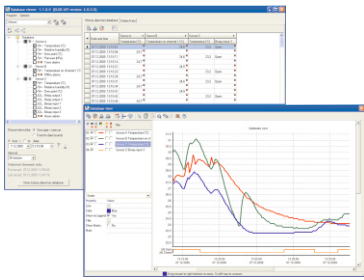

**DBS**

**DBS Sensor Monitor** - - database program  
 - enables online data acquisition and analysis of actually measured and stored values from unlimited number of Comet sensors connected to Ethernet  
 - it is a data acquisition system of client-server type  
 - it contains:  
 \* software for server computer:  
 \* SOAP server for data acquisition  
 \* Administration program database  
 \* MySQL or Microsoft SQL database server (third party freeware)  
 \* one licence of DBV Database Viewer.  
 More information at page 72.

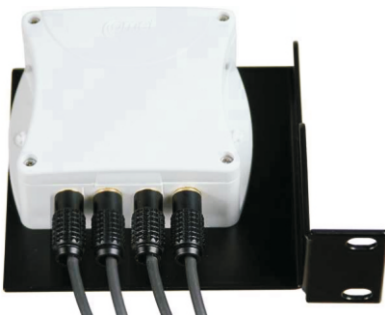

**MPO46**

Universal holder for Tx51x, P85x transmitters for easy mounting to rack 19".



**MPO47**

Universal holder for probes for easy mounting to rack 19"  
 (probes not included).

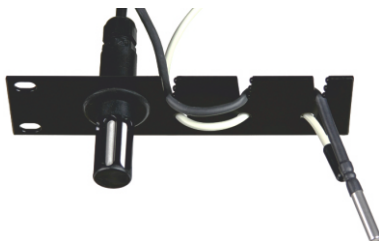

**Pt1000 probes**

Temperature probes for **Tx51x transmitters** with Pt1000 RTD sensor without connector - there is a symbol /O behind probe name.  
 Recommended is watertight probe Pt1000TR160/O on the shielded PVC cable 2 x 0.14mm<sup>2</sup>. Specify required cable length 1, 2, 5, 10, 15 or 20 meters.  
 Enclosure diameter 6mm, length 20mm.  
 Diameter of the cable 3.5mm.



**DWLP50**

DWL-P50 Power over Ethernet (PoE) adapter from company D-Link.  
 The adapter is supposed to be connected to Ethernet switch supporting PoE.



**A1515**

AC/DC adapter 230V-50Hz/12V for transmitter range Tx51x.